

BELT DRYER BD 3000/16 KTA Zorbau (DEU)



Thermal recycling plant for waste
Green box: Exterior view of the dryer building and dry material storage silo



View from the end of Belt Dryer BD 3000/16 with
Return module and Exhaust air fan

In the **Zorbau** waste incineration plant, downstream of the turbine, a part of the steam volume is used for drying digested or stabilized, dewatered sewage sludge resulting from the treatment of municipal wastewater. In 2017, a fully automated sewage sludge drying plant (KTA) with a **Belt Dryer BD 3000/16** with 16 modules was commissioned for this purpose.

The sludge is transported by LAV (Landwirtschaftliches Verarbeitungszentrum Makranstädt) from various storage facilities and stored in one of the two **inground bunkers**. Via hydraulically operated moving floors and a trough chain conveyor, the dewatered sludge is fed to the integrated **back-mixing system**. The back-mixing is done with dried material in a twin-screw mixer to a DS content > 30 %. The sludge conditioned in this way is fed evenly and with **increased surface area** onto the upper dryer belt by the Distributor/Dosing unit and Roller press. After drying to 90 % DS, the sludge is homogenized to **4 mm grain size** in a roller mill, cooled, transported and stored in the dry material storage silo.

The hot air required for drying is generated by **heat exchangers supplied with hot steam** in the respective mixing chambers of the dryer modules. Fresh supply air is introduced through manually adjustable supply air dampers.

The circulating air fans of the mixing chamber convey the drying air into the process chamber across the transport direction of the sludge layer. The hot air cools down during the process and absorbs the evaporated water. The exhaust air loaded with evaporated water is removed from the system via exhaust air flaps in the process chamber of the dryer module. Ambient air and exhaust air from the inground bunker serve as supply air for the drying process. The supply air is **preheated with steam condensate as well as superheated steam** before entering the dryer. The humid exhaust air from the dryer is returned to the waste incineration plant in a non-condensed state.

PreZero Energy Zorbau GmbH (and previous operators) has operated a thermal recycling plant in Zorbau since 2005 and treats about 300,000 tons of waste per year.

The plant processes waste from parts of the German states of Saxony, Saxony-Anhalt, Thuringia and Lower Saxony to thermal recycling. The energy and steam generated by waste incineration is converted into electricity and district heating and fed into the public grid.



SEVAR

Drying Technologies

FUNCTIONAL PRINCIPLE

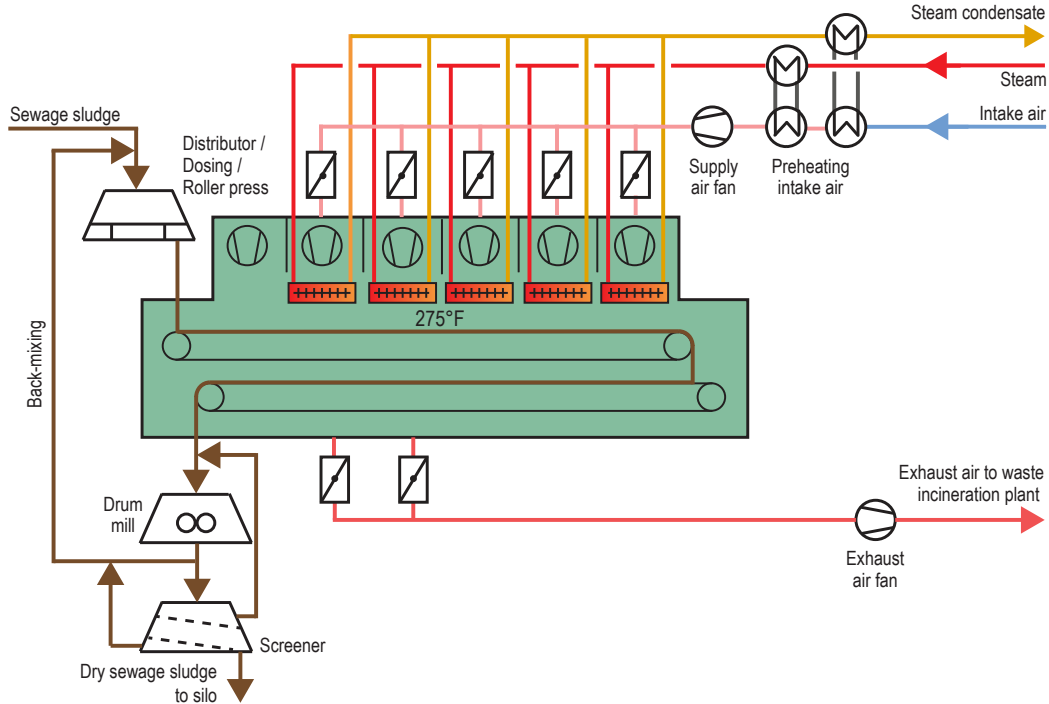

Source: SEVAR AG

TECHNICAL DATA

t = tn.sh. (US unit)

Scope of supply:	Belt Dryer BD 3000/16 with building, wet cake reception bunker, conveying systems, impurity separator, roller mill for product crushing, screener, dry material storage silo
Type of drying:	Full drying
Heating source:	Indirect heating: Steam from waste incineration plant with 340 °F, drying temperature: approx. 275 °F
Material:	Digested or stabilised dewatered municipal sludge
DS input:	20 - 30%
DS output:	90%
Throughput_wet:	55,100 t/a (6.9 t/h) [110,200,000 lb/a (13,800 lb/h)]
Water evaporation:	5.0 t H ₂ O/h [9,900 lb/h]
Operating hours:	24 h/d, fully automatic
Commissioning:	2017

SEVAR AG

SEVAR AG emerged in 2020 from the environmental technology division of Haarslev Industries A/S. The over 30 years proven **technology of belt drying** is continued under the already wellknown name SEVAR with a motivated team. The young German company with headquarters and production near Karlsruhe is supported by an international network of partners and agents.

SEVAR designs and manufactures equipment for the **thermal treatment of municipal and industrial sewage sludge**, biomass and digestate. The treatment of the humid exhaust air resulting from the drying process with **condensation and odor control** is also considered. Reference plants are available for visiting worldwide.

We reserve the right to alter the specifications at any time without prior notice.