

BELT DRYER BD 1500/2 SAUR Crolles (FRA)



Belt Dryer BD 1500/2 inside building

For the **Stel II** project, the French company **NIJHUIS SAUR INDUSTRIES** placed an order with SEVAR AG in March 2022 for a **belt dryer of the size BD 1500/2** including delivery, installation supervision and support during commissioning. Due to its compact dimensions with $L \times W \times H = 7.8 \times 3.6 \times 4.2$ m, the belt dryer was transported completely assembled by a heavy-duty truck from the factory in Karlsdorf-Neuthard to the installation building in Crolles near Grenoble in France. A second truck transported the external auxiliaries such as exhaust fan, feed unit, discharge screw, back-mixing unit consisting of trough chain conveyor, dosing screw, double-shaft mixer.

Surplus sludge from the **biological treatment of industrial wastewater from the semiconductor industry, dewatered to 16% DS by a screw press, is dried to > 60% DS** with a designed throughput of 144 kg/h in the two modules of the belt dryer. The feed unit of the belt dryer consisting of distributor, dosing unit and roller press granulates the supplied material prior to drying. For optimal drying, an internal back-mixing system is installed. In this process, dried material is mixed with the dewatered sludge to 30% DS. The material to be dried is thus given a volume-to-surface ratio favorable for water transfer to the drying air.

A hot water circuit from the production process of the chip manufacturer STMicroelectronics with a flow temperature of 65 °C and a return temperature of 54 °C is used to generate the drying air at 57 °C. The water circuit is used to heat the material to be dried. The water circuit heats the dryer air indirectly via heat exchangers installed in the mixing chamber of the two dryer modules. During the drying process, **106 kg/h of water are evaporated**. The dryer is designed for 12, 16 or 24 operating hours per day. At maximum load, the dryer achieves a water evaporation capacity of 154 kg/h at feed/return temperatures of 75/55 °C of the hot water circuit with 7.5 m³/h.

The dried sewage sludge is collected in containers and transported to the **cement plant for co-combustion**. The humid exhaust air from the dryer is fed to the plant's own exhaust air treatment system, consisting of an acid and a basic scrubber.



Back-mixing: Trough chain conveyor transports dry sludge into dosing screw

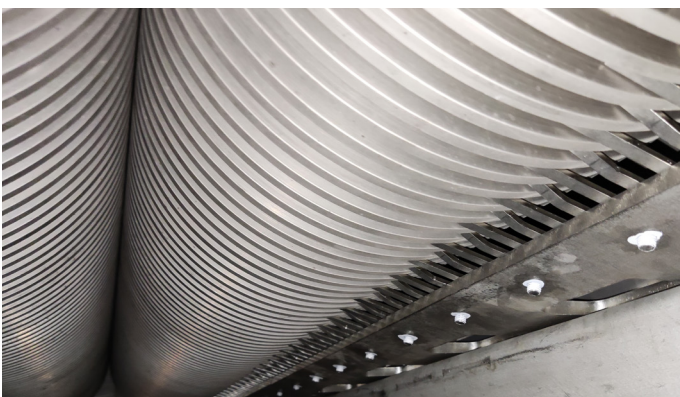

Roller press with scrapers (view from below)

FUNCTIONAL PRINCIPLE

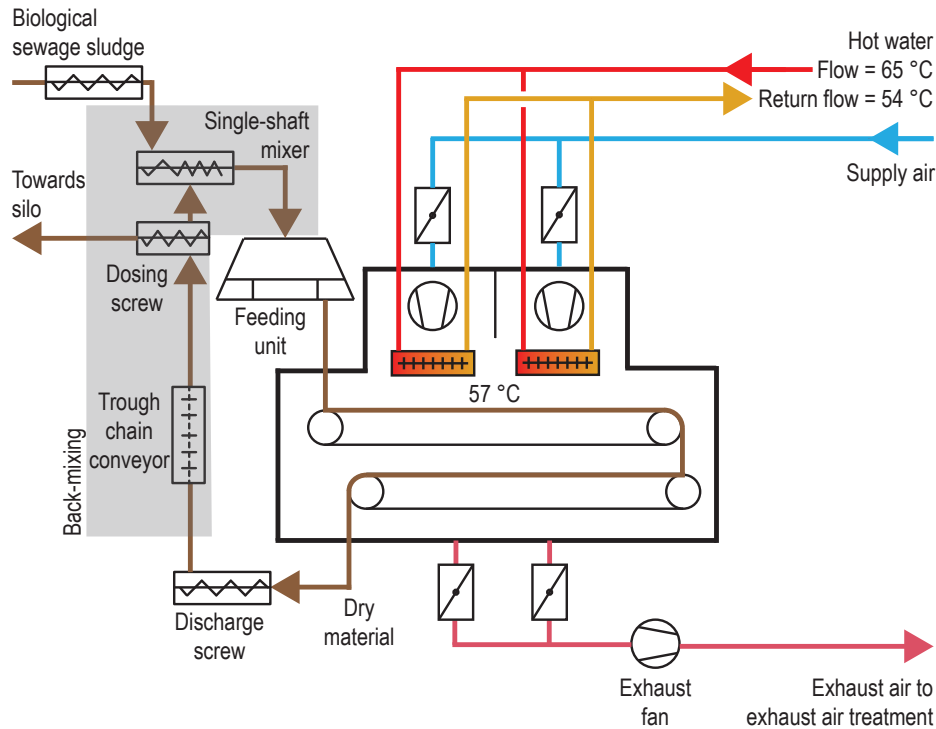

Source: SEVAR AG

TECHNICAL DATA

Scope of supply:	Belt dryer BD 1500/2 with dosing screw dewatered sludge, discharge screw dried sludge, back-mixing (trough chain conveyor, dosing screw, single-shaft mixer).
Type of drying:	Partial drying
Heating source:	Indirect heating with hot water (65/54 °C)
Material:	Sludge from aerobic biological treatment of wastewater from the semiconductor industry
DS input:	18 %
DS output:	>60 %
Throughput_wet:	115 t/a (144 kg/h) / 18,4 t _{DS} /a
Water evaporation:	106 kg H ₂ O/h
Operating hours:	24 h/d, fully automatic
Commissioning:	2023

SEVAR AG

SEVAR AG emerged in 2020 from the environmental technology division of Haarslev Industries A/S. The over 30 years proven **technology of belt drying** is continued under the already well-known name SEVAR with a motivated team. The young German company with headquarters and production near Karlsruhe is supported by an international network of partners and agents.

SEVAR designs and manufactures equipment for the **thermal treatment of municipal and industrial sewage sludge**, biomass and digestate. The treatment of the humid exhaust air resulting from the drying process with condensation and odor control is also considered. Reference plants are available for visiting worldwide.

We reserve the right to alter the specifications at any time without prior notice.