

BELTDRYER 2x BD 3000/6 Opole (PL)



One line of BD 3000/6 belt dryer with feeding unit

In 2013, SEVAR AG installed **two (2) lines of the Belt Dryer BD 3000/6** with a **water evaporation capacity in total of 2,100 kg H₂O/h** in the sludge treatment building of the Opole Municipal Wastewater Treatment Plant, a city in Poland. Independent operation of both lines is possible. The general contractor was the Polish engineering company **SEEN Technologie**.

Yearly 24,000 t of digested sewage sludge with a DS content of approx. 25% are dried to 90% DS with the two lines of the Belt Dryer BD 3000/6.



Wet and acid scrubber for exhaust gas

The **hot cooling water of the CHP units** with a temperature of approx. 95 °C is used in an **indirect heating system consisting of tube-bundle heat exchangers** to heat the drying gas to an average temperature of 80 °C. In the event of a malfunction of the CHP unit, hot water is produced with a natural gas boiler. In a heat recovery system, the humid exhaust air (approx. 60 °C) is used to preheat the fresh supply air in a heat exchanger, and the exhaust gas is cooled down to approx. 45 °C. The exhaust air is then used for the drying process. Approx. 5 - 10% exhaust air is continuously extracted from the drying system, which has entered the system as false air via the dryer's feeding unit. The **treatment of the exhaust gas** (approx. 18,000 Nm³/h) takes place in a directly operated air scrubber and then in a chemical scrubber and biofilter. The effluent from the wastewater treatment plant is used as washing water for the air scrubber. The resulting condensate or sludge is discharged to the Opole wastewater treatment plant for treatment.



Exterior view building sludge treatment

The dried sewage sludge is transported to the **roller mill** by a screw conveyor so as not to exceed a **particle size of 8 mm**. The particle size is required for thermal disposal of the sewage sludge. After drying, the material is stored in a silo for dry material. If the silo is full, it is possible to operate the screw conveyor in reverse and store the dry product in containers.

FUNCTIONAL PRINCIPLE

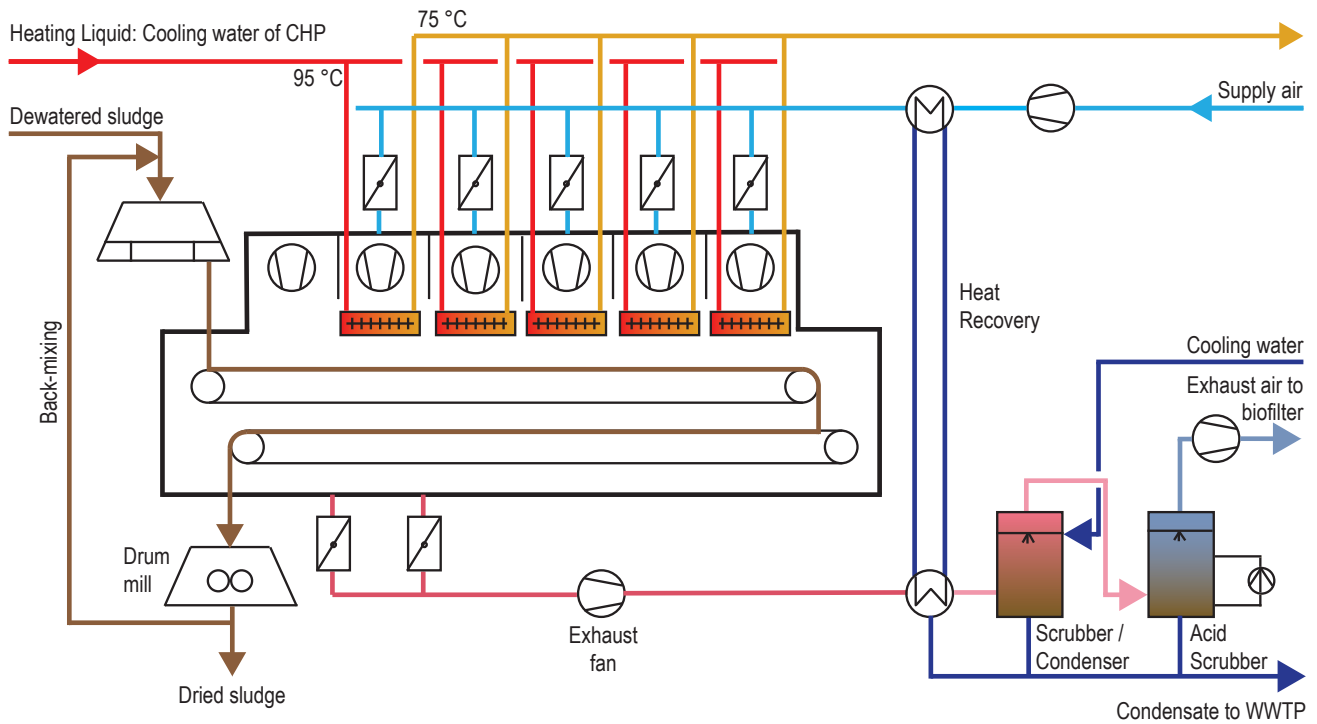

Quelle: SEVAR AG

TECHNICAL SPECIFICATION

Scope of supply:	2 lines of Belt Dryer BD 3000/6 with waste heat recovery, exhaust air treatment with wet scrubber, acid scrubber, drum mill and reversed operating discharge screw conveyor
Type of drying:	Full-drying
Heating source:	Indirect heating: hot water from the CHP [95/75 °C], drying temperature in the range of 75 - 85 °C
Material:	Digested, dewatered municipal sewage sludge
DS input:	25 %
DS output:	90 %
Throughput:	24.000 t/a (3.000 kg/h)
Water evaporation:	2.100 kg H ₂ O/h
Operating hours:	24 h/d, fully automatic
Commissioning:	2013

SEVAR AG:

SEVAR AG emerged in 2020 from the environmental technology division of Haarslev Industries A/S. The over 30 years proven technology of **belt drying** is continued under the already well-known name SEVAR with a motivated team. The young German company with headquarters and production near Karlsruhe is supported by an international network of partners and agents.

SEVAR designs and manufactures plants for the **thermal treatment of municipal and industrial sewage sludge**, fermentation residues and wood residues. The treatment of the humid exhaust air resulting from the drying process with **condensation and odour treatment** is also considered. Reference plants are available for inspection worldwide.

We reserve the right to alter the specifications at any time without prior notice.