

BELT DRYER BD 3000/6 Oak Harbor, WA (USA)



Belt Dryer BD 3000/6 with air duct, inlet unit and wet cake storage hopper

In 2015, the well-known construction and civil engineering company Hoffman Constructions Group ordered a complete **Biosolids Belt Dryer System** from SEVAR AG for the full drying of undigested, dewatered waste activated sludge (WAS) produced during wastewater treatment at the **Oak Harbor Wastewater Treatment Plant**. Oak Harbor is a city located on Whidbey Island in Washington State on the U.S. West Coast. To protect the environment, for urban development, and to recover resources from wastewater, the City of Oak Harbor started the **Clean Water Facility Project** in 2010. In 2018, the wastewater treatment plant went into operation. (www.oakharborcleanwater.org/)



Chain conveyor (wet product) to inlet unit (Distributor-/Dosing-unit) on access platform

The surplus bacteria mass resulting from the aerated biological wastewater treatment (MBR) is dewatered to an average of 17.5% TR using centrifuges and stored in the wet cake storage hopper. The sewage sludge, dried to 90% TR by the **Belt Dryer BD 3000/6**, is transported to the truck receiving point by a conveyor system. The dry granules are trucked away and used as high quality fertilizer for golf courses, community gardens and other places.

The scope of supply of SEVAR consisted of one belt dryer with back-mixing and access platform, wet cake storage hopper, pumps, conveyors, hot air generation by burner, direct exhaust air condensation and plant control including PLC and programming, which provides a complete integrated system. Support during installation, commissioning and training of the plant staff as well as the provision of a project engineer are also part of SEVAR's scope.



Tubular drag chain conveyor (dry product) to crusher (drum mill)

The throughput of the dryer is 1.9 t/h [3,800 lb/h] wet biosolids with an average of 17.5% DS. The water evaporation capacity is 1.5 t_{H₂O}/h [3,000 lb/h]. Sewage sludge dried to 90% TR at 0.4 t/h [800 lb/h] is discharged via the dryers discharge screw. The annual operating time of the belt dryer is 3,700 h with an operation of 24 h/d. A final bulk density of 25 lb/ft³ [400 kg/m³] is reached by crushing of the dry biosolids to 1-4 mm.



SEVAR

Drying Technologies

FUNCTIONAL PRINCIPLE

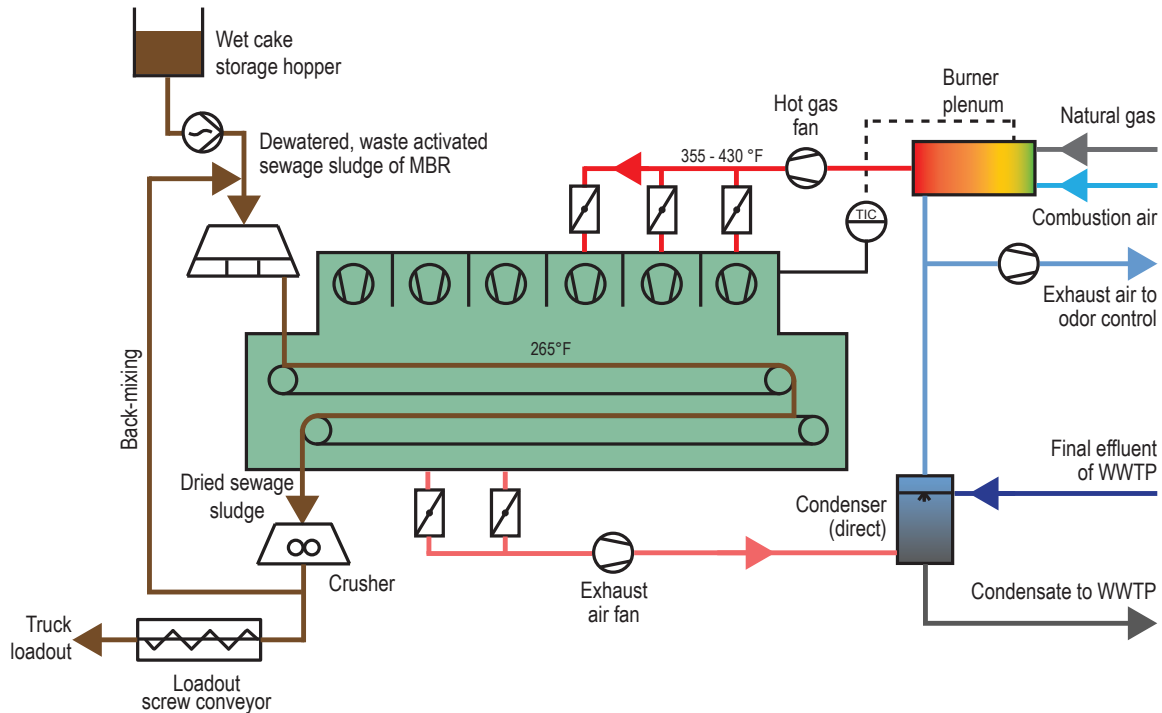

Source: SEVAR AG

TECHNICAL DATA

t = tn.sh. (US unit)

Scope of supply:	Belt Dryer BD 3000/6 with wet cake storage hopper and access platform, feed pumps for dewatered sewage sludge, back-mixing, burner plenum, direct operated spray condenser, dry product crusher, screw conveying system, PLC and programming
Type of drying:	Full drying
Heating source:	Direct heating with natural gas
Material:	Undigested waste activated sewage sludge (WAS)
DS input:	16-19%
DS output:	90%
Throughput_wet:	6,600 t/a (1.9 t/h) [13,200,000 lb/a (3,700 lb/h)]
Water evaporation:	1.5 t H ₂ O/h [3,100 lb/h]
Operating hours:	24 h/d, 3,500 h/a, fully automatic
Commissioning:	2018

SEVAR AG

SEVAR AG emerged in 2020 from the environmental technology division of Haarslev Industries A/S. The over 30 years proven **technology of belt drying** is continued under the already wellknown name SEVAR with a motivated team. The young German company with headquarters and production near Karlsruhe is supported by an international network

of partners and agents. SEVAR designs and manufactures equipment for the **thermal treatment of municipal and industrial sewage sludge**, biomass and digestate. The treatment of the humid exhaust air resulting from the drying process with condensation and odor control is also considered. Reference plants are available for visiting worldwide.

We reserve the right to alter the specifications at any time without prior notice.

Oak Harbor, WA (USA)