

BELT DRYER BD 3000/7 Locminé, Liger (FRA)



Belt dryer BD 3000/7 with exhaust air ducts



Exhaust air fan



Circulation air fan and condensation

In the department of Morbihan, since 2011, the French town of Locminé and its surrounding area, through the mixed-economy company **LIGER** (Locminé Innovation Management of Renewable Energies), have built a unique **bioenergy center** with 10 employees on a 4-ha site in the industrial park.

Unique in Europe, it is the first site to combine two green energy sources: Combustion of wood waste and methanization of digestate to produce electricity, heat, green fuel and fertilizer. The wood-fired heating plant is supplied with 3500 t/a of tree trimmings and by-products from sawmills. The methanization plant is operated with 60,000 t/a of organic material from a 20 km radius. The liquid digestate is used for agriculture and the solid digestate is used as fuel. Incoming biogas is utilized in a CHP plant for electricity and heat. The **heat** is used to produce hot water for feeding into the hot water network and for **indirect heating of the belt dryer**.

In 2015, SEVAR was contracted to install a **turnkey digestate drying plant** with a throughput of 14,000 t/a [28,000,000 lb/a] of digestate. The wet product with approx. 25 % DS from two centrifuges is fed to the **Belt Dryer BD 3000/7** with seven modules via pumps. The feeding unit consisting of distributor, dosing unit and roller press distributes and granulates the product evenly onto the upper dryer belt with a width of 3 meters. The **perforated stainless steel dryer belt** transports the digestate at a speed of approx. 0.2 m/min. (variable frequency) through the modules of the dryer.

The humid air leaving the belt dryer at approx. 20,000 Nm³/h is cooled in the **condenser** and then treated chemically (acidic and basic) and in the biofilter.

The dry material, dried to 80-85% DS and crushed, is transported into skips via a screw distribution system and stored.



SEVAR

Drying Technologies

FUNCTIONAL PRINCIPLE

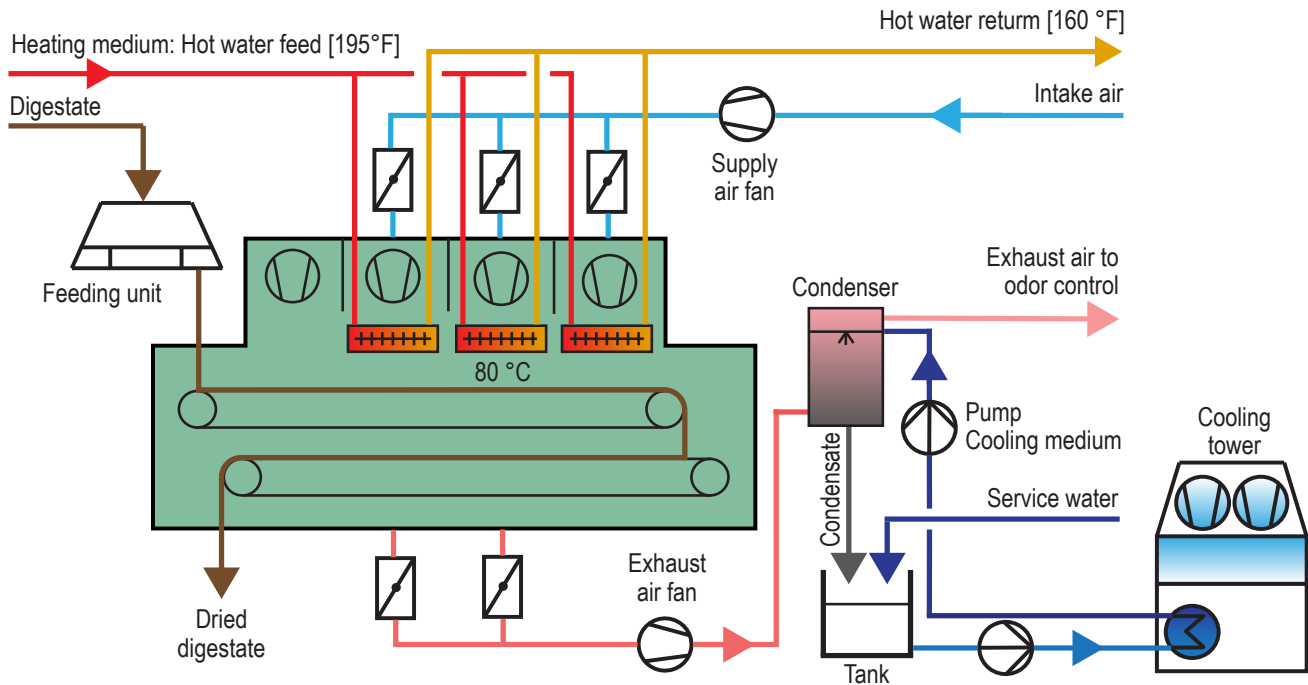

Source: SEVAR AG

TECHNICAL SPECIFICATION

t = tn.sh. (US unit)

Scope of supply:	Belt dryer BD 3000/7 with outlet air cooler
Type of drying:	Full-drying
Heating source:	Indirect heating
Material:	Methanization digestates
DS input:	25 %
DS output:	80-85 %
Throughput_wet:	14.000 t/a (1.8 t/h) [28,000,000 lb/a (3,500 lb/h)]
Water evaporation:	1.2 t H ₂ O/h [2,500 lb H ₂ O/h]
Operating hours:	24 h/d, fully automatic
Commissioning:	2018

SEVAR AG

SEVAR AG emerged in 2020 from the environmental technology division of Haarslev Industries A/S. The over 30 years proven **technology of belt drying** is continued under the already wellknown name SEVAR with a motivated team. The young German company with headquarters and production near Karlsruhe is supported by an international network of partners and agents.

SEVAR designs and manufactures equipment for the **thermal treatment of municipal and industrial sewage sludge**, biomass and digestate. The treatment of the humid exhaust air resulting from the drying process with condensation and odor control is also considered. Reference plants are available for visiting worldwide.

We reserve the right to alter the specifications at any time without prior notice.