

BELT DRYER BD 3000/6 CTBM Quebec (CAN)



Belt Dryer BD 3000/6 with feeding unit, discharge screw, inlet air duct



Supply air fan with heat exchanger and horizontal condenser



Pre-dried material above roller press for transfer to upper dryer belt

CTBM - *Centre de Traitement de la Biomasse de la Montérégie* is an organic waste management center for the treatment of liquid and semi-liquid residues from the agricultural and food industries in Canada. The center is equipped with three digesters and a secondary digester for biomethanization of the biogenic residues to produce biogas. A part of biogas is used as energy for the center, while the other part is injected into the public utility grid.

Since 2023 CTBM has been operating a **Belt Dryer BD 3000/6** for drying pre-dried **organic residues (digestate) of anaerobically digested compost (80%) mixed with wood chips (20%)**. The organic mixture to be dried is fed onto the 3 m wide upper dryer belt via the feed unit consisting of a distributor, dosing unit and roller press. In the modules of the dryer, the humid material comes into contact with the circulating drying air, which is heated in the range of 100 - 130 °C, for more than one hour. In the six modules the humid exhaust air is removed from the process and condensed recycled supply air is passed over heat exchangers for heating and passed through the product layers on the two dryer belts by means of circulation fans. **The heat exchangers are operated with 250 °C thermal oil.** The thermal oil is centrally heated by a biogas/natural gas burner and used to heat the dryer, digesters and other plant equipment in the circuit. The humid warm exhaust air from the dryer passes through a 315 kW high capacity heat exchanger to produce about 20 m³/h of 65 °C warm water. The exhaust air condenses in the indirect water-operated horizontal condenser installed downstream and cools to 40 °C. The condensate is sent to the nearest wastewater treatment plant via the sewage system. Approx. 90% of the condensed exhaust air is returned to the dryer.

By adjusting the speed of the supply and exhaust air fans, a slight vacuum of 2 - 4 mbar is created in the belt dryer to prevent odors from leaking out. However, this allows leakage air to enter the system via the dryer's feed unit. The exhaust air fan removes the leakage air from the system at a rate of 2,500 m³/h in balance terms to the odor control system. The odor control process consists of an acid and basic scrubber.

SEVAR

Drying Technologies

FUNCTIONAL PRINCIPLE

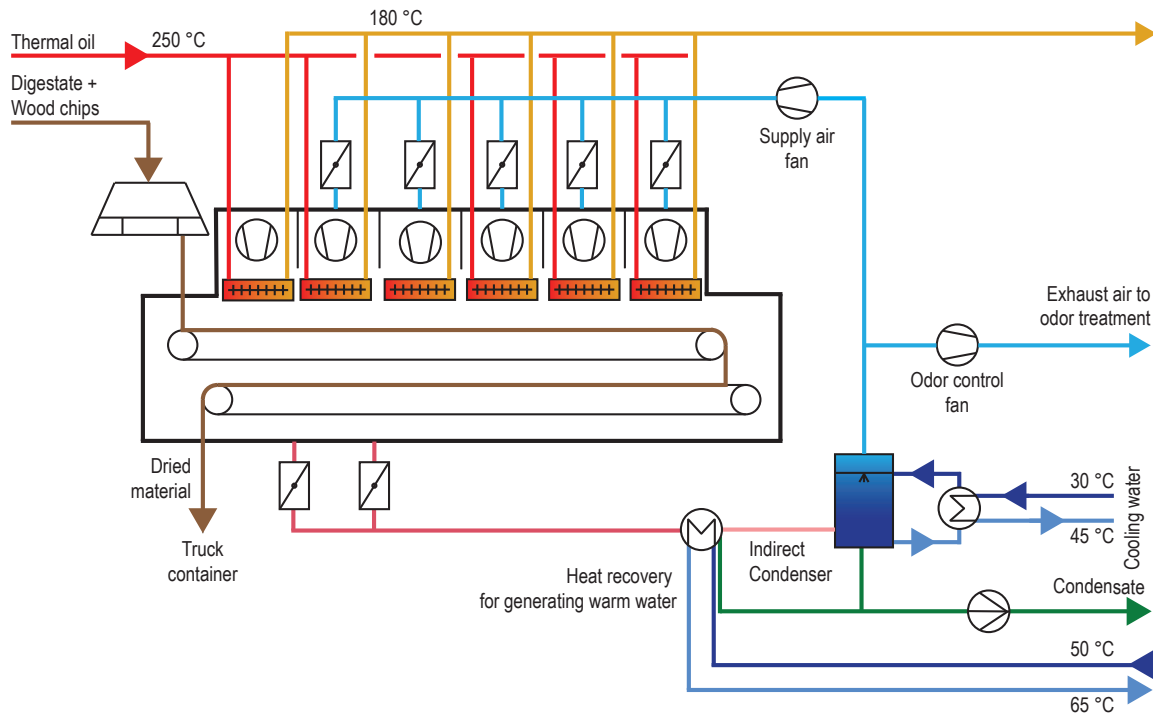

Source: SEVAR AG

TECHNICAL DATA

Scope of supply:	Belt Dryer BD 3000/6 belt dryer with chain conveyor for feeding, indirectly operated horizontal spray condenser, heat exchanger for generation of 65 °C warm water
Type of drying:	Full drying
Heating source:	Indirect heating with thermal oil
Material:	Organic residues (digestate) of anaerobically digested compost (80%) mixed with wood chips (20%)
DS input:	38%
DS output:	83%
Throughput_wet:	18,500 t/a (2,300 kg/h) / 7,000 t _{DS} /a
Water evaporation:	1,250 kg H ₂ O/h
Operating hours:	24 h/d, fully automatic
Commissioning:	2023

SEVAR AG

SEVAR AG emerged in 2020 from the environmental technology division of Haarslev Industries A/S. The over 30 years proven **technology of belt drying** is continued under the already well-known name SEVAR with a motivated team. The young German company with headquarters and production near Karlsruhe is supported by an international network of partners and agents.

SEVAR designs and manufactures equipment for the **thermal treatment of municipal and industrial sewage sludge**, biomass and digestate. The treatment of the humid exhaust air resulting from the drying process with condensation and odor control is also considered. Reference plants are available for visiting worldwide.

We reserve the right to alter the specifications at any time without prior notice.