

BELTDRYER BD 3000/6 Albstadt (DEU)



Belt Dryer BD 3000/6 with material return module and exhaust air ducts

The city of Albstadt in Baden-Württemberg ensures a permanent, environmentally friendly and cost-effective **sewage sludge disposal for the municipal sewage treatment plant** as well as for the sewage treatment plants in the regional surroundings. For this purpose, a biomass cogeneration plant with sewage sludge drying has been realized at the Albstadt-Ebingen wastewater treatment plant.

In 2009, SEVAR was awarded for the construction of a turnkey **sewage sludge drying plant** with a throughput of 12,000 t/a sewage sludge with an average dry solids content of 30%.

The **Belt Dryer BD 3000/6** consists of six drying modules. Adjacent to the dryer building, a receiving bunker with a moving floor is utilized to store the delivered sewage sludge with a volume of 120 m³. A trough chain conveyor transports the sludge to the feeding unit of the belt dryer and distributes it over the width of the belt of 3 m.

The **dryer belts made of stainless steel** with slotted perforations convey the sludge at a speed of approx. 0.2 m/min (FU-controlled). The residence time of the material in the dryer is 120 - 180 min, depending on the belt speed. The humid exhaust air extracted from the belt dryer (approx. 20,000 Nm³/h) is cleaned in the chemical scrubber (acid/caustic) and then in the biofilter (surface area: 100 m²). The condensate accumulates in the biofilter.

The sewage sludge, dried to 90 % dry residue and crushed to 1 - 4 mm in a roller mill, is **stored in a 150 m³ silo** and utilized as a fuel substitute (calorific value similar to lignite) in a regional cement factory.



Chemical scrubbers (acidic & caustic)



Biofilter

SEVAR

Drying Technologies

FUNCTIONAL PRINCIPLE

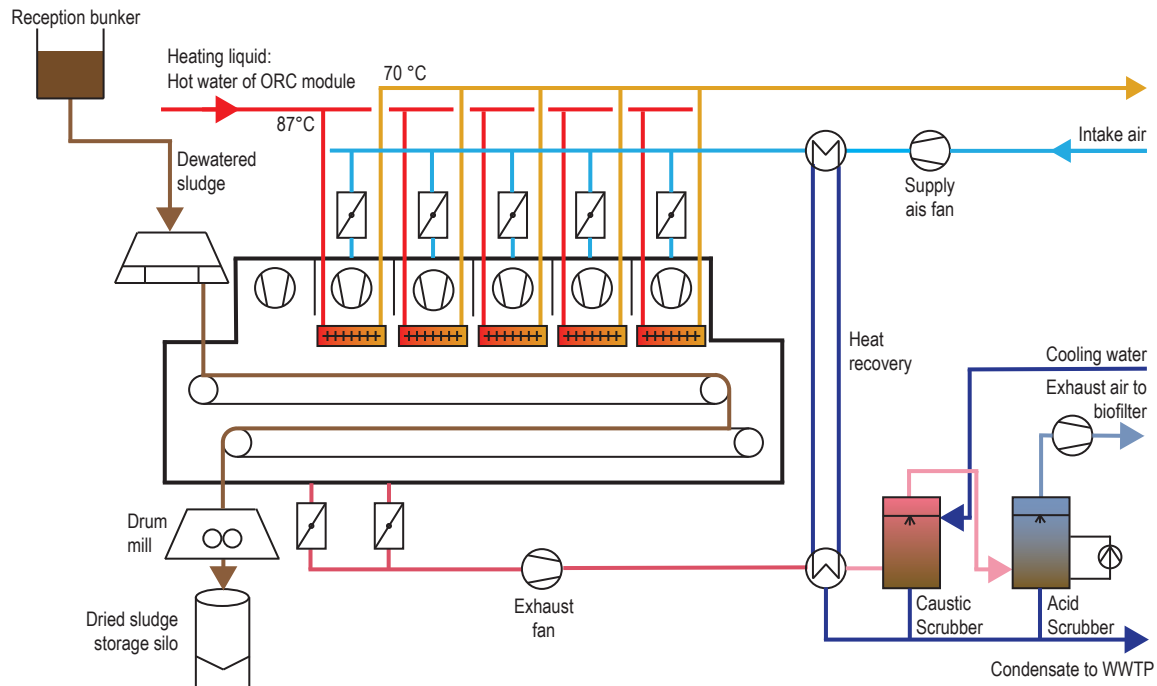

Source: SEVAR AG

TECHNICAL SPECIFICATION

Scope of supply:	Belt Dryer BD 3000/6 with reception bunker and storage silo, exhaust air treatment with chemical scrubbers and biofilter
Type of drying:	Full-drying
Heating source:	Indirect Heating: Hot water of ORC-module [87/70 °C], with combustion of biomass, Drying temperature: approx. 80 - 85 °C
Material:	Digested municipal sewage sludge
DS input:	30 %
DS output:	90 %
Throughput:	12.000 t/a (1.500 kg/h)
Water evaporation:	1,000 kg H ₂ O/h
Operating hours:	24 h/d, fully-automatic
Commissioning:	2011

SEVAR AG

SEVAR AG emerged in 2020 from the environmental technology division of Haarslev Industries A/S. The over 30 years proven technology of **belt drying** is continued under the already well-known name SEVAR with a motivated team. The young German company with headquarters and production near Karlsruhe is supported by an international network of partners and agents.

SEVAR designs and manufactures plants for the **thermal treatment of municipal and industrial sewage sludge**, fermentation residues and wood residues. The treatment of the humid exhaust air resulting from the drying process with **condensation and odour treatment** is also considered. Reference plants are available for inspection worldwide.

We reserve the right to alter the specifications at any time without prior notice.